

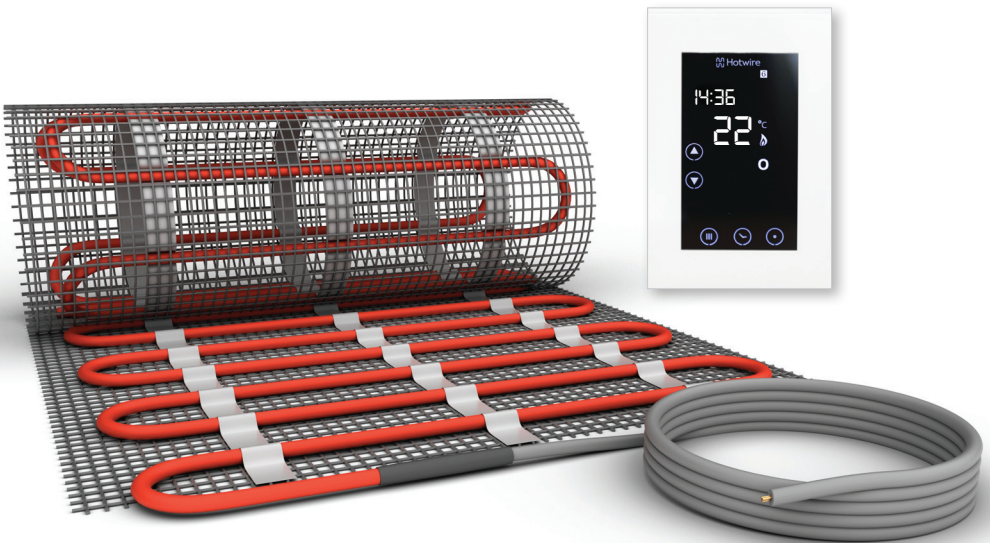

Hotwire In Screed Heating Mat Installation

Included In Each Package:

*In Screed Heating Mat Touch Screen
Thermostat Continuity Tester
(Alarm) Adhesive Tape
Instructions*



Contents

General.....	Page 3
Floor Preparation.....	Page 3
Marking the floor for mat installation	Page 3
Prior to the Installation of the element.....	Page 4
Installation of the element	Page 5
Floor probe (Sensor) & Cold Tails	Page 6
Do's and Don'ts	Page 7
Tiling Instructions	Page 8
Avoid the following	Page 8
Customer Warranty	Page 9

This product is In Screed Heating. It is designed to be installed in a Sand and Cement Screed.

If you are looking to install your floor heating immediately under the tiles, you will need the Hotwire Under Tile Heating Mat.

Please read the instructions prior to your installation: The incorrect installation of the heating element may lead to damage and would invalidate your warranty

GENERAL:

1. The heating mat must only be installed as per the Hotwire instructions.
2. The heating mat **MUST NOT** be cut or shortened or the cold tail join be put under any strain
3. In accordance with the local electricity laws an authorised electrician must carry out all prescribed electrical work.
4. Your Hotwire element is classified as an electrical appliance. All electrical connections including the connection of the thermostat must be undertaken by a licensed electrician.
5. **IMPORTANT:** A certificate of Compliance (COC) must be issued by the electrician once the installation has been completed. Your electrician may need to check and test the mat installation prior to any floor covering being laid including the screed.
6. The design wattage for Hotwire mats is 200 watts per m².
7. The mat width is 450mm wire to wire.
8. Subfloor: It is essential that the subfloor is sufficiently rigid to support the heating elements and not allow unnecessary movement.

FLOOR PREPARATION:

1. Floors must be entirely clean, dry and level. If necessary sand or grind the floor first. Clean working surfaces will provide good adhesion.
2. If a timber subfloor is being used, then we recommend tile and Slate underlay being installed prior to the elements to give the floor the rigidity required. This is especially important if the subfloor is tongue and groove flooring.
3. Water proofing membrane requirements are determined on installation methods and are subject to local council requirements/ regulations.
4. Where there is no water proofing, the floor must be painted with primer and allowed to dry for 30-40 minutes. This will ensure good adhesion for taping down the element.

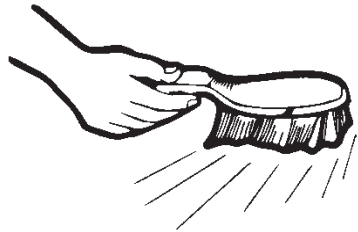

MARKING THE FLOOR FOR MAT INSTALLATION:

1. Mark the floor with a marker pen or crayon to show the exact area to be heated. Be sure not to lay elements in areas that may have floor fixtures installed after tiling (vanities, showers, toilets, and doorstops etc) The minimum spacing between 2 runs of the mat is 50mm and the maximum should be no more than 80mm to achieve efficient heat distribution.
2. Calculate the exact "net m2 heating area" based on your floor plan. Hotwire In Screed Heating Mats are installed at 200 watts per m2. When measuring the net floor area, measure off the walls, benches and shower trays the distance you require.

PRIOR TO THE INSTALLATION OF THE ELEMENT:

1. Before starting, use a multi-metre to check the resistance on the cable ensuring there is a circuit. Note the correct ohms reading (-5 + 10%) which is labelled on each cable outer packaging.
2. Prior to starting your installation, a flush box needs to be prepared for your thermostat.

Note:

The Thermostat that comes with the system can be mounted horizontally or vertically. The heating element must be protected by an RCD with a rated residual operating current not exceeding 30mA. An electrician must either install a dedicated RCD or use an existing one.

3. Plan your laying path in advance, starting directly below your flush-box position.
4. You can lay the mat in any configuration you want as long as the spacing is even over the total area to be heated. See examples below.

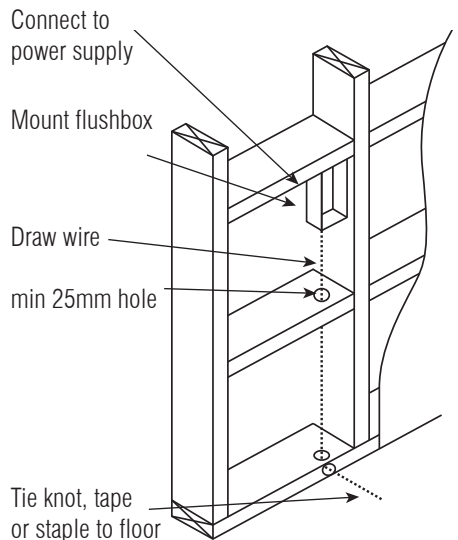
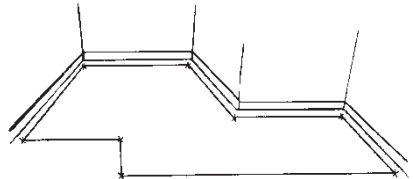

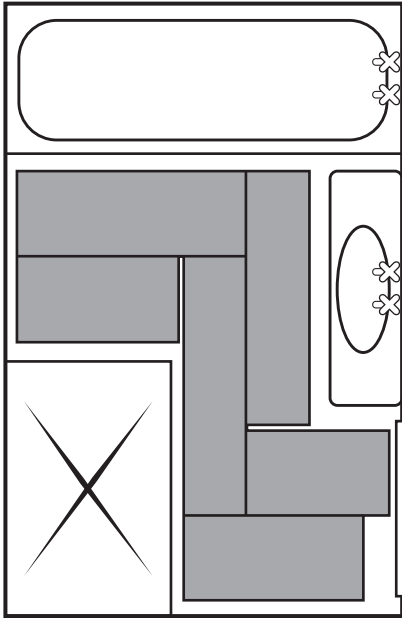

START

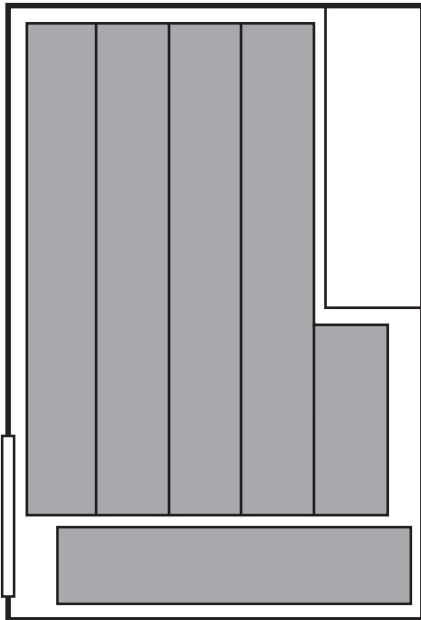

START

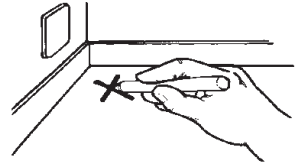

INSTALLATION OF THE ELEMENT:

1. Secure the heating element using a hot glue gun or tape. Make sure no part of the element lifts from the floor surface. This will ensure no damage occurs while screeding or tiling. The use of a spray adhesive along the areas where the cable loops acts as a primer for the tape which will also ensure no lifting occurs.
2. Once you are about 50% through the installation of the heating mat, it is recommended to unroll the remainder of it to ensure you are on target with your initial laying calculations.
3. The mat must be turned when reaching an end wall. To do this cut the tape/mesh from the mat nearest the wall, and turn the mat and place parallel to the existing lane. (Ensure even spacing between lanes is maintained.)

Note:

If you have excess element remaining, you may go back and uplift a percentage of the mat, cut the tapes/ mesh then free spool the extra element out across the floor. Never cut the cable (shorten) and remember that the spacings should be kept as even as possible.

Test the element again to ensure correct ohms reading after installation and prior to any screed being laid.

FLOOR PROBE (SENSOR) & COLD TAILS:

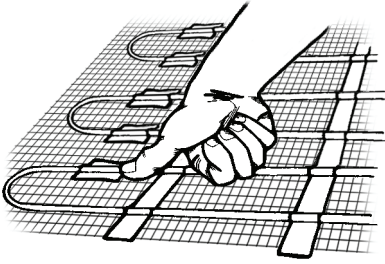

1. Recess the probe flat onto the floor approximately 50mm from the heating element. This is to ensure that it obtains the correct temperature readings. Use hot glue to hold it in place.

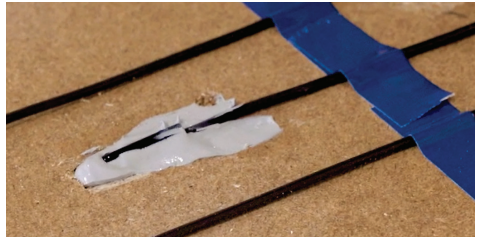
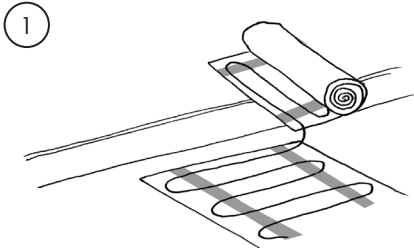

2. The probe wire must NOT cross over the heating element.
3. Ensure that there is enough probe wire to go up to the controller with the cold tail.
4. Attach a draw wire to the ends of both cold tail as well as the floor probe wire.
5. Gently pull up inside the wall so that the cold tail and probe wire can reach the flush box.
6. NEVER allow the heating element to be within the wall cavity.
7. Tape the cold tail to the flush box to avoid them dropping back down inside the wall.
8. Attach the continuity tester included in the kit to the cold tail of the element as per the instructions. This will ensure that any subsequent work on the floor will be monitored for damage.

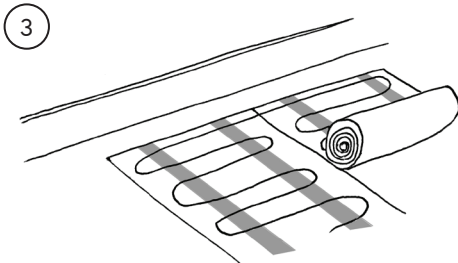
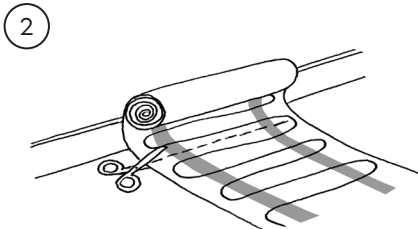

9. Prior to tiling AVOID ANY UNNECESSARY foot traffic on the element. If the floor is not being tiled /screeded immediately, a sheet of cardboard should be laid over the element as an interim measure.
7. Protect the element prior to tiling
8. Check the element again for resistance readings prior to tiling starting and when tiling be very careful not to damage the element.
9. Use Tile adhesives and grouts that are suitable for use with underfloor heating.
10. Ensure that each tile is solidly bedded in adhesive with no air gaps.
11. If you are unsure of any aspect of the installation or the suitability of the subfloor to be heated, check with your supplier (place of purchase) or call 1300 HEATING for technical advice.

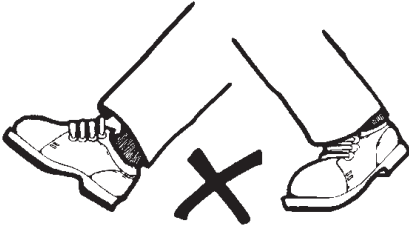

DO'S AND DON'TS:

Do's

1. Read the installation instructions prior to the installation.
2. Ensure the surface is clean and clear of obstructions
3. Plan the heat mat layout prior to installation.
4. Pre-plan post drilling Eg: doorstops vanities etc to eliminate damage to the element.
5. Before starting and after laying use a multi-metre to check the resistance on the cable ensuring there is a circuit.
6. Ensure that all heating element is positioned on the floor and not up into the wall cavity.

Don'ts

1. Don't cut or attempt to shorten the element.
2. Don't commence installation on concrete floors that are not fully cured.
3. Don't allow the heating element to cross over or touch - nor cross over into another room.
4. Don't allow the element to be installed on irregular surfaces.
5. Don't commence tiling before checking the continuity tester is working and that it is fitted to the elements cold tails.
6. Don't turn on the heating until the adhesives has fully cured (7 days)

ELECTRICAL SPECIFICATIONS OF HEATING MATS:

m2	Watts	Ohms	Amps
1	200	264.50	0.87
1.5	300	176.33	1.30
2	400	132.25	1.74
2.5	500	105.80	2.17
3	600	88.17	2.61
3.5	700	75.57	3.04
4	800	66.13	3.48
4.5	900	58.78	3.91
5	1000	52.90	4.35
6	1200	44.08	5.22
7	1400	37.79	6.09

TILING INSTRUCTIONS:

1. Always use a flexible adhesive.
2. We recommend the use of a notched trowel and if possible a plastic trowel.
3. To eliminate the risk of damage to the heating cables, you may choose to apply a self levelling compound (screed) Ensure that levelling compounds are used as per the manufacturers instructions. (In particular for non-concrete floors)
4. A cement based grout should be used with no less than 10% latex content. (Latex modified acrylic, PVA,SBR)
5. Always move your trowel in the same direction as the heating elements
6. Use sufficient adhesive to eliminate voids or hollows under the tile.
7. Be careful when removing excess adhesive when scraping between tiles.

AVOID THE FOLLOWING:

1. Cutting tiles over the heating elements.
2. Dropping tools or sharp objects onto the elements.
3. Don't wear hard soled shoes.
4. When lifting misplaced tiles ensure that you DO NOT lift the heating cable.

CUSTOMER WARRANTY AGAINST DEFECTS FOR HOTWIRE UNDER TILE HEATING PRODUCTS

Turnkey International Pty Ltd (ABN 36 086 830 766) trading as Hotwire Heating (Hotwire)

About Our Products

Hotwire Heating products are made of high quality heating cable with FEP (teflon) insulated conductor, braided screen and a black PVC outer sheath providing invisible, comfortable, fast, dust-free, quiet and energy saving floor heating solution.

All Hotwire Floor Heating systems include:

- Heating Element
- Fully programmable Touch Screen Thermostat
- Alarm
- Tape
- Installation Manual
- Temperature Probe

Wi-Fi and Dual Thermostats are available as an upgrade.

Hotwire Heating warrants that all of our under the floor heating cables are free from defects in material and workmanship in their manufacture. Our under the floor heating cables are carefully tested, including resistance measurement and 1500V insulation test (high voltage test) before their shipment, and are well packed to avoid damage during transit.

Availability Of Installation And Servicing

Hotwire Heating products are provided based on the measurement of the floor You are wanting to cover. If You need an installer, we can help there too. Hotwire was the largest network of qualified floor heating installers in Australia. Simply look up the closest installer to You on our "Installations" page.

AUSTRALIAN CONSUMER LAW WARRANTIES

Hotwire Heating's Goods come with guarantees that cannot be excluded under the Australian Consumer Law (ACL).

Under ACL, Consumers who have been supplied our Goods by a builder, a third party, or who have purchased a home in which our Goods are installed are entitled to access to repair/replacement parts, a guarantee that the Goods are of acceptable quality and the express warranties below. These Consumers are not entitled to the same rights as a Consumer who has purchased Goods directly from Hotwire Heating.

EXPRESS WARRANTIES

Hotwire Heating provides support to Consumers (regardless of whether they purchased Goods directly from Hotwire Heating or not), in respect of Goods supplied by Hotwire Heating. This may involve Hotwire Heating attending Your property to assess the issues with the Goods and if the issue is a major defect of Goods or a manufacturing fault (subject to Hotwire Heating's Terms and Conditions and the provisions of this Consumer Warranty), then Hotwire Heating will attend to

rectification of the issue, at the cost of Hotwire Heating. If the issue is not a major defect of Goods or a manufacturing defect with the Goods, then Hotwire Heating may be able to assist You in resolving the issue, and will discuss with You what can be done and the costs associated.

Often, issues arise from the Goods having not been installed by a licensed electrician, or having been installed incorrectly. Hotwire Heating supplies an Installation Manual to all purchasers at the time of sale of the Goods and advises purchasers that the Goods must be installed by a licensed electrician in accordance with the Installation Manual. If the Goods are not installed by a licensed electrician in accordance with the Installation Manual, this will void any warranty applicable to the Goods. In these circumstances, Hotwire Heating may be able to assist the Consumer in any issues with the Goods (at the cost of the Consumer), however, Hotwire Heating is not liable for issues arising from installation of the Goods either:

- By a person who is not a licensed electrician; or
- Resulting from failure to install the Goods in accordance with the Installation Manual.

Extended Warranty

Hotwire Heating undertakes to repair or, at its sole discretion, to replace any part of the Goods supplied by Hotwire Heating which are found to have a manufacturing defect for a period of 10 years from the date of purchase, save that any warranty in relation to the thermostat and the controller of the Goods is limited to 2 years.

Your obligations

In order to make a claim on the Goods and Services of Hotwire Heating, either under the ACL or the Extended Warranty provided herein, the Consumer must cease using the

Goods immediately, contact Hotwire Heating from the outset of the issue, prior to engaging any tradespersons or attempting to repair the Goods, and must follow any reasonable instructions or provide any reasonable information requested by Hotwire Heating.

Any repairs or replacement of the Goods must be performed by Hotwire Heating (or its authorised contractors). Hotwire Heating shall not be responsible for any repairs performed to the Goods without the knowledge or authority of the Hotwire Heating.

EXCLUSIONS

Hotwire Heating does not provide Statutory Warranties or Extended Warranties in any of the following circumstances:

1. The Purchaser/Consumer fails to comply with Hotwire Heating's Installation Manual in relation to the fitting, installation and use of the Goods;
2. The Goods installed by non-Hotwire Installer or a person who was not a licensed electrician;
3. Unauthorised repairs or alterations made to the Goods;
4. Goods being subjected to improper voltage or power surges, misused, damaged by accident, force of nature or any other acts beyond Hotwire Heating's reasonable control;
5. The Goods being improperly installed or installed other than strictly in accordance with the Installation Manual (other than where such improper or other installation is carried out by an Authorised Installer);
6. The Consumer failing to provide the required document called "Hotwire Element Testing" upon request;
7. The Consumer failing to provide Proof of purchase (clearly stating the date of purchase);
8. Where there is a failure to complete the Hotwire Element Testing process, as set

out in the Hotwire Heating Element Booklet; or

9. Calls to replace batteries, programme re-program thermostats and/or controllers, replace fuses or reset residual current devices or circuit breakers.

The total maximum liability of Hotwire Heating in all cases (save for those under ACL) is limited to replacing the Goods, repairing the Goods or repayment of the purchase price of the Goods, whichever is the lesser.

Hotwire Heating will not be liable for any incidental expenses (including costs of inspection, testing, removal, reinstallation, storage or transportation), any other charges, costs or expenses of the Consumer or any third party, personal injury, incidental damages, consequential losses, loss of profit, costs of business interruption, loss of opportunities or any like claims whatsoever arising from any use of, or incidental to, the Goods or their failure to operate.

If any component or part of the Goods is manufactured by a third party or supplied to Hotwire Heating by a third party, any warranty offered by Hotwire Heating in relation to the Goods or a component part of the Goods will be limited to Hotwire Heating's right of redress (if any) against the manufacturer or supplier of the component part of the Goods.

How to claim under warranty

Claims under warranty must be made by contacting the Hotwire Heating on the telephone number, email or postal address below:

Hotwire Heating

Factory 1 / 7-9 Newcastle Rd,
Bayswater Vic 3153

Telephone: 1300 797 060

Email: info@hotwireheating.com.au

1300 468 947
hotwireheating.com.au

Copyright 2023 Hotwire IP Pty Ltd. All rights reserved. This article may not be reproduced, distributed, or transmitted in any form or by any means, including photocopying, recording, or other electronic or mechanical methods, without the prior written permission of the copyright holder.

12-12

Hotwire (Australia Head Office)
Factory 1 / 7-9 Newcastle Rd
Bayswater Vic 3153

Phone 1300 468 947
www.hotwireheating.com.au

 **Hotwire**
FLOOR HEATING